

35N-2

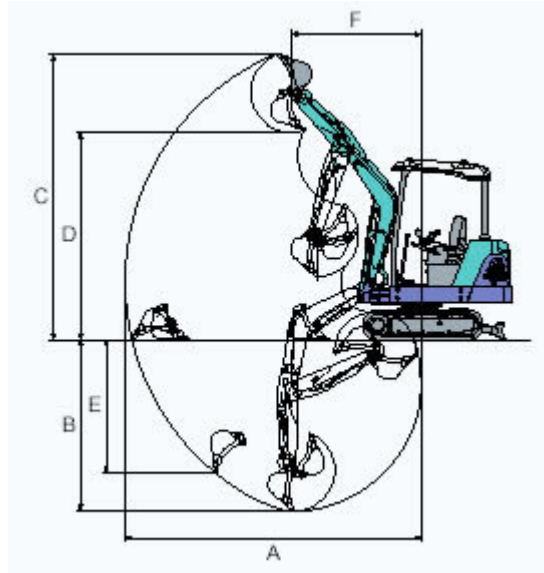
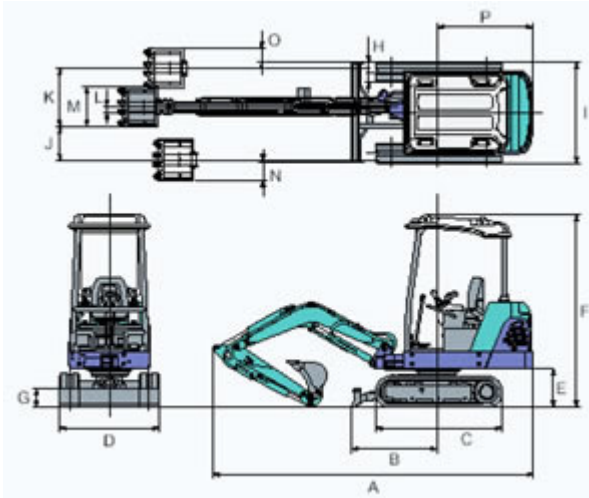

Dims. for 35N-2			
A	15'11"	I	5'1"
B	5'2"	J	1'10"
C	6'9"	K	1'6"
D	5'1"	L	2"
E	1'1"	M	1'8"
F	7'8"	N	2"
G	1'2"	O	2"
H	1'2"	P	4'2"

Working Ranges 35N-2		
A	Max Digging Radius	16'8"
B	Max Digging Depth	10'4"
C	Max Digging Height	15'7"
D	Max Dumping Height	10'10"
E	Max Vertical Digging Depth	8'0"
F	Min Front Turning Radius	6'4"
	At Right Boom Swing	5'6"
	Digging Force	7,662 lbs

Specifications			
Basic Specifications		Hydraulic Equipment	
Canopy	4 Post / Cabin	Pumps	4
Bucket Capacity	3.90 cu. Ft.	Type-Piston/Gear	2 Piston / 2 Gear
Operating Weight	7,759 lbs.	Total Flow	27.1 gpm
Transports Weight	7,216 lbs.	Operating Pressure	2,988 psi
		Auxiliary Flow	16.7 gpm
Engine		Dimensions	

Model	Yanmar 3TNV84	Length	15'11"
Horsepower	26.5 @ 2,300 rpm	Width	5'1"
Fuel Tank Capacity	9.8 gals	Height	7'8"
Features			
Travel Speed L/H	1.7/3.0 mph		
Ground Pressure	4.1 psi		
Swing Speed	8.8 rpm		
Swing Angle	L50°/R90°		