

# 28N-2

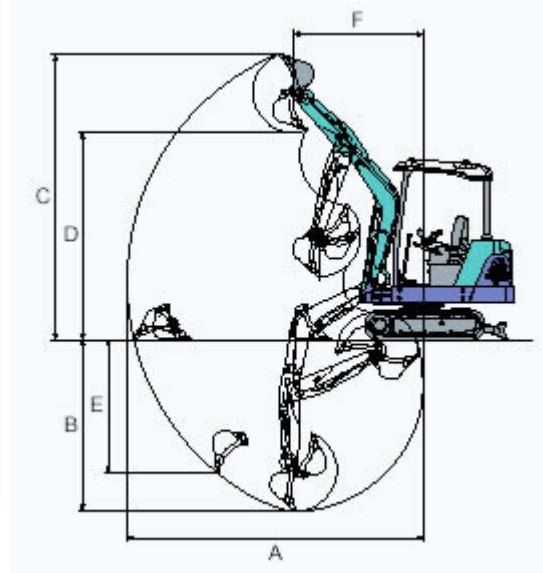
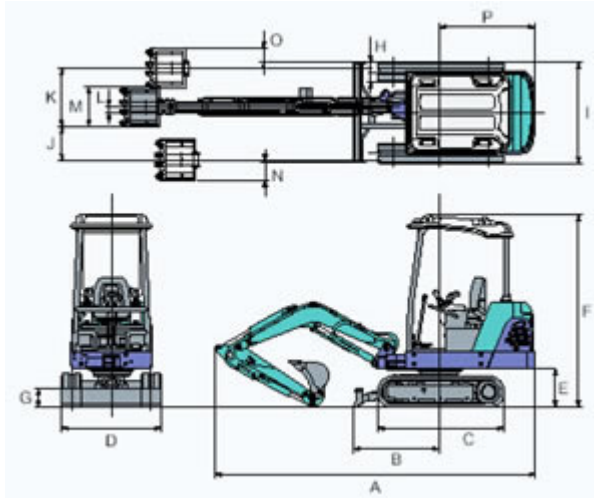

Dims. for 28N-2			
<b>A</b>	13'8"	<b>I</b>	1'10"
<b>B</b>	3'10"	<b>J</b>	1'6"
<b>C</b>	6'3"	<b>K</b>	2"
<b>D</b>	5'1"	<b>L</b>	1'8"
<b>E</b>	1'0"	<b>M</b>	2"
<b>F</b>	7'7"	<b>N</b>	2"
<b>G</b>	1'2"	<b>O</b>	4'2"
<b>H</b>	5'1"	<b>P</b>	

Working Ranges 28N-2		
<b>A</b>	Max Digging Radius	14'2"
<b>B</b>	Max Digging Depth	8'3"
<b>C</b>	Max Digging Height	13'3"
<b>D</b>	Max Dumping Height	9'4"
<b>E</b>	Max Vertical Digging Depth	6'5"
<b>F</b>	Min Front Turning Radius	6'5"
	At Right Boom Swing	4'2"
	Digging Force	5,460 lbs.

Specifications			
Basic Specifications		Hydraulic Equipment	
Canopy	4 Post / Cabin	Pumps	4
Bucket Capacity	2.80 cu. ft.	Type-Piston/Gear	2 Piston / 2 Gear
Operating Weight	6,189 lbs.	Total Flow	20.3 gpm
Transports Weight	5,742 lbs.	Operating Pressure	2,988 psi
		Auxiliary Flow	12.7 gpm

Engine		Dimensions	
Model	Yanmar 3TNV76	Length	13'8"
Horsepower	21.1 @ 2,300 rpm	Width	5'1"
Fuel Tank Capacity	9.8 gals	Height	7'7"
Features			
Travel Speed L/H	1.5/2.8 mph		
Ground Pressure	3.8 psi		
Swing Speed	10 rpm		
Swing Angle	L50°/R90°		