

# 80NX-3

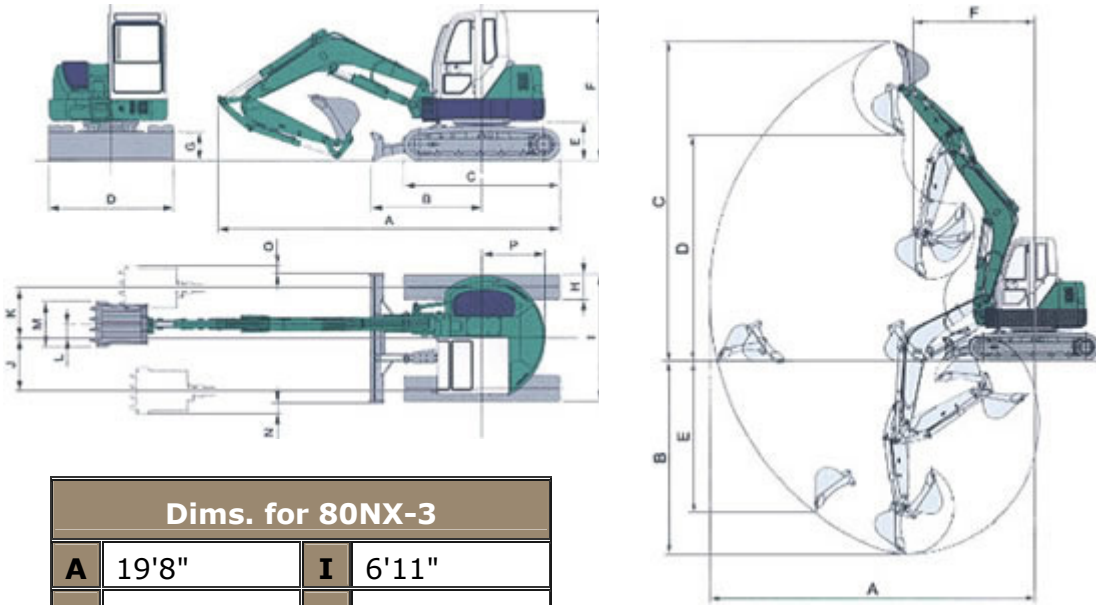

Dims. for 80NX-3			
<b>A</b>	19'8"	<b>I</b>	6'11"
<b>B</b>	6'4"	<b>J</b>	4'4"
<b>C</b>	8'11"	<b>K</b>	4'1"
<b>D</b>	7'3"	<b>L</b>	9"
<b>E</b>	2'3"	<b>M</b>	2'6"
<b>F</b>	8'6"	<b>N</b>	8"
<b>G</b>	1'8"	<b>O</b>	6"
<b>H</b>	1'6"	<b>P</b>	4'3"

Working Ranges 80NX-3		
<b>A</b>	Max Digging Radius	23'4"
<b>B</b>	Max Digging Depth	15'1"
<b>C</b>	Max Digging Height	22'9"
<b>D</b>	Max Dumping Height	14'3"
<b>E</b>	Max Vertical Digging Depth	10'10"
<b>F</b>	Min Front Turning Radius	8'5"
	At Right Boom Swing	7'3"
	Digging Force	14,730 lbs

Specifications			
Basic Specifications		Hydraulic Equipment	
Canopy	4 Post/Cabin	Pumps	4
Bucket Capacity	8.8 cu. Ft.	Type-Piston/Gear	2 Piston / 2 Gear
Operating Weight	18,100 lbs	Total Flow	51.8 gpm
Transports Weight	17,635 lbs	Operating Pressure	3,550 psi
		Auxiliary Flow	18.9 gpm

Engine		Dimensions	
Model	Isuzu AA-4JG1	Length	19'8"
Horsepower	56.3 @ 2,100 rpm	Width	7'3"
Fuel Tank Capacity	18.5 gals	Height	8'5"
Features			
Travel Speed L/H	1.6/2.7 mph		
Ground Pressure	5.2 psi		
Swing Speed	9.2 rpm		
Swing Angle	L50 /R80		