

# 35NX-2

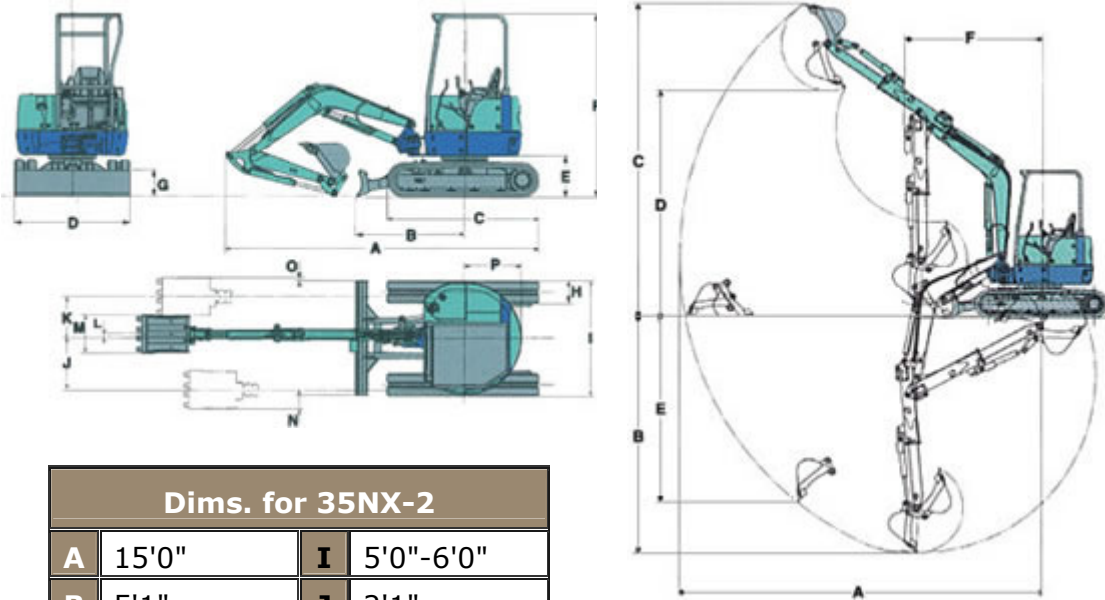

Dims. for 35NX-2			
<b>A</b>	15'0"	<b>I</b>	5'0"-6'0"
<b>B</b>	5'1"	<b>J</b>	2'1"
<b>C</b>	7'3"	<b>K</b>	1'8"
<b>D</b>	5'0"	<b>L</b>	2"
<b>E</b>	1'10"	<b>M</b>	2"
<b>F</b>	8'1"	<b>N</b>	7"
<b>G</b>	1'2"	<b>O</b>	2"
<b>H</b>	1'0"	<b>P</b>	2'9"

Working Ranges 35NX-2		
<b>A</b>	Max Digging Radius	17'9"
<b>B</b>	Max Digging Depth	11'4"
<b>C</b>	Max Digging Height	15'11"
<b>D</b>	Max Dumping Height	11'1"
<b>E</b>	Max Vertical Digging Depth	9'8"
<b>F</b>	Min Front Turning Radius	7'2"
	At Right Boom Swing	5'8"
	Digging Force	7,688 lbs

Specifications			
Basic Specifications		Hydraulic Equipment	
Canopy	4 Post/Cabin	Pumps	4
Bucket Capacity	3.9 cu. Ft.	Type-Piston/Gear	2 Piston / 2 Gear
Operating Weight	7,440 lbs	Total Flow	27.1 gpm
Transports Weight	7,275 lbs	Operating Pressure	2,990 psi
		Auxiliary Flow	16.7 gpm

Engine		Dimensions	
Model	Yanmar 3 TNV84	Length	15'0"
Horsepower	26.5 @ 2,300 rpm	Width	5'0"
Fuel Tank Capacity	10.6 gals	Height	8'1"
Features			
Travel Speed L/H	1.7/3.0 mph		
Ground Pressure	4.6 psi		
Swing Speed	8.8 rpm		
Swing Angle	L50°/R90°		