

# 25NX-2

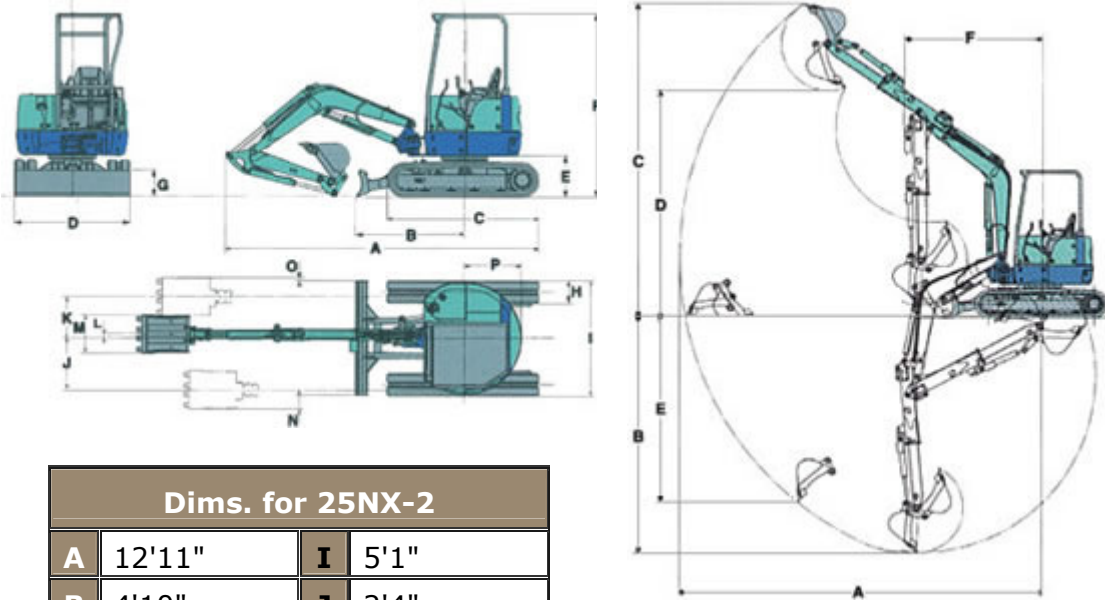

Dims. for 25NX-2			
<b>A</b>	12'11"	<b>I</b>	5'1"
<b>B</b>	4'10"	<b>J</b>	2'4"
<b>C</b>	6'3"	<b>K</b>	1'10"
<b>D</b>	5'1"	<b>L</b>	2"
<b>E</b>	1'10"	<b>M</b>	1'8"
<b>F</b>	8'1"	<b>N</b>	7"
<b>G</b>	1'2"	<b>O</b>	1.4"
<b>H</b>	1'2"	<b>P</b>	2'6.5"

Working Ranges 25NX-2		
<b>A</b>	Max Digging Radius	14'9"
<b>B</b>	Max Digging Depth	8'3"
<b>C</b>	Max Digging Height	13'3"
<b>D</b>	Max Dumping Height	9'0"
<b>E</b>	Max Vertical Digging Depth	6'5"
<b>F</b>	Min Front Turning Radius	6'4"
	At Right Boom Swing	4'11"
	Digging Force	5,698 lbs

Specifications			
Basic Specifications		Hydraulic Equipment	
Canopy	4 Post/Cabin	Pumps	4
Bucket Capacity	2.80 cu ft.	Type-Piston/Gear	2 Piston / 2 Gear
Operating Weight	6,100 lbs.	Total Flow	20.2 gpm
Transports Weight	5,849 lbs	Operating Pressure	2,988 psi
		Auxiliary Flow	12.7 gpm

Engine		Dimensions	
Model	Yanmar 3TNV76	Length	12'11"
Horsepower	21.1 @ 2,300 rpm	Width	5'1"
Fuel Tank Capacity	9.8 gals	Height	8'1"
Features			
Travel Speed L/H	1.5/2.8 mph		
Ground Pressure	3.9 psi		
Swing Speed	10 rpm		
Swing Angle	L50°/R90°		