

15NX-2

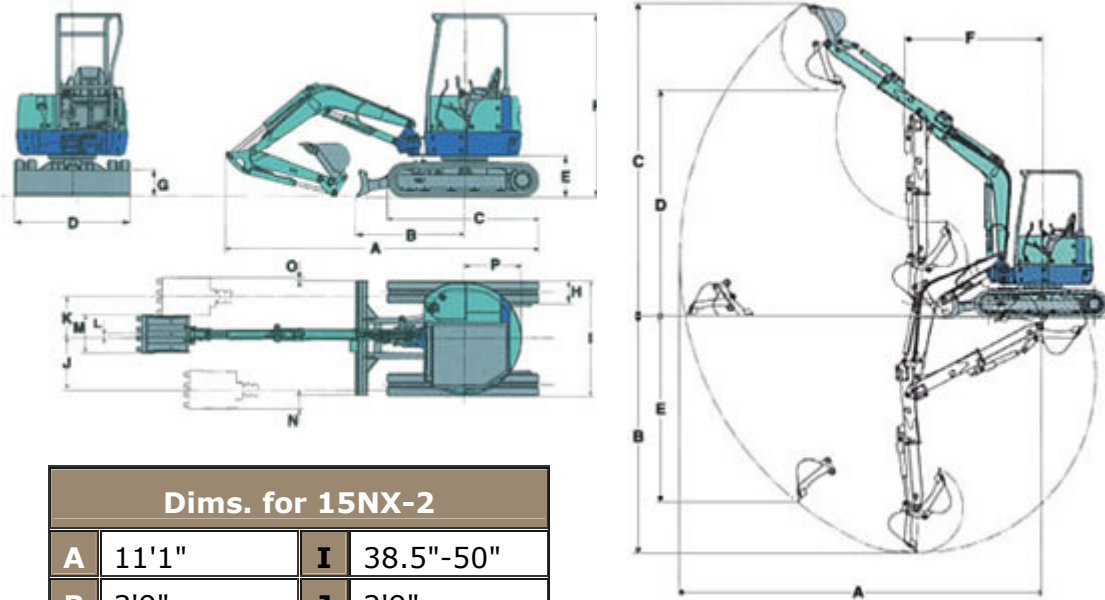

Dims. for 15NX-2			
A	11'1"	I	38.5"-50"
B	3'9"	J	2'9"
C	5'2"	K	2'9"
D	3'3"	L	2"
E	1'6"	M	1'4"
F	7'6"	N	1'2"
G	9"	O	1'2"
H	9"	P	2'2"

Working Ranges 15NX-2		
A	Max Digging Radius	12'4"
B	Max Digging Depth	7'0"
C	Max Digging Height	11'10"
D	Max Dumping Height	8'5"
E	Max Vertical Digging Depth	5'10"
F	Min Front Turning Radius	4'11"
	At Right Boom Swing	4'2"
	Digging Force	5,447 lbs

Specifications			
Basic Specifications		Hydraulic Equipment	
Canopy	4 Post	Pumps	4
Bucket Capacity	1.55 cu. Ft.	Type-Piston/Gear	2 Piston / 2 Gear
Operating Weight	3,850 lbs.	Total Flow	12.7 gpm
Transports Weight	3,600 lbs	Operating Pressure	2,988 psi
		Auxiliary Flow	6.9 gpm

Engine		Dimensions	
Model	Yanmar 3TNV70	Length	11'1"
Horsepower	14 @ 2,300 rpm	Width	3'3"
Fuel Tank Capacity	5.3 gals	Height	7'6"
Features			
Travel Speed L/H	1.3/2.5 mph		
Ground Pressure	3.7 psi		
Swing Speed	9,5 rpm		
Swing Angle	L55 /R80		