

9NX-2

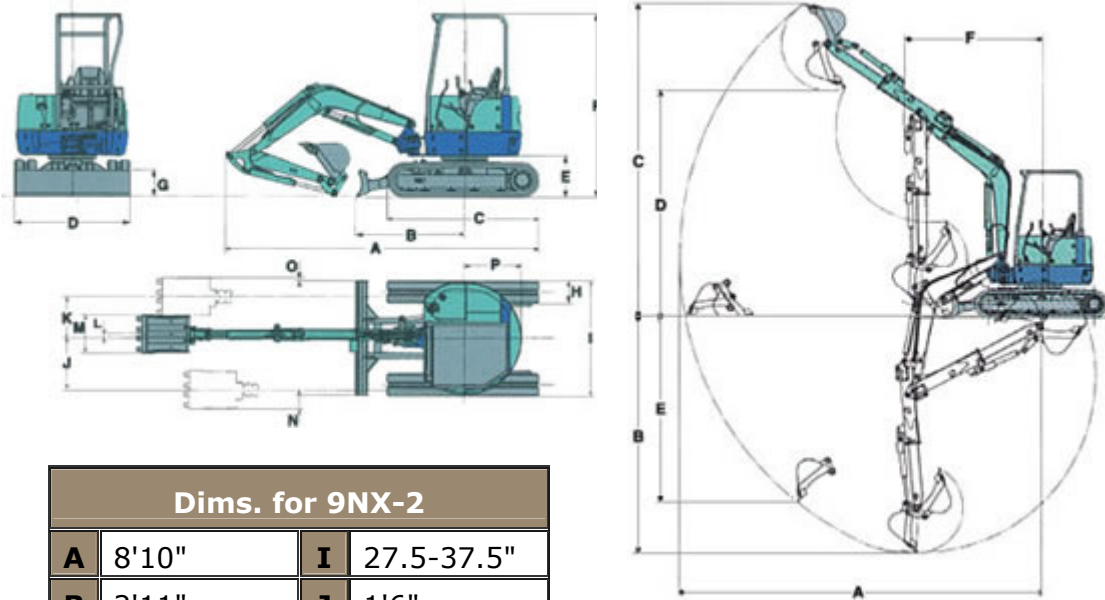

Dims. for 9NX-2			
A	8'10"	I	27.5-37.5"
B	2'11"	J	1'6"
C	3'11"	K	1'7"
D	2'3.5"	L	3"
E	1'4"	M	1'3"
F	6'10"	N	11'
G	9.5"	O	7"
H	7"	P	

Working Ranges 9NX-2		
A	Max Digging Radius	9;9"
B	Max Digging Depth	5'2"
C	Max Digging Height	9'0"
D	Max Dumping Height	6'6"
E	Max Vertical Digging Depth	3'10"
F	Min Front Turning Radius	4'0"
	At Right Boom Swing	3'1"
	Digging Force	2,360 lbs

Specifications			
Basic Specifications		Hydraulic Equipment	
Canopy	4 Post	Pumps	2
Bucket Capacity	.80 cu. Ft.	Type-Piston/Gear	2 Gear
Operating Weight	2,060 lbs.	Total Flow	5.9 gpm
Transports Weight	1,885 lbs.	Operating Pressure	2,350 psi
		Auxiliary Flow	5.9 gpm

Engine		Dimensions	
Model	Yanmar 2TNV70	Length	8'10"
Horsepower	10 @2,400 rpm	Width	2'3.5"
Fuel Tank Capacity	2.2 gals	Height	7'5"
Features			
Travel Speed L/H	1.1/2.2 mph		
Ground Pressure	3.8 psi		
Swing Speed	8.7 rpm		
Swing Angle	L50°/R90°		