



OPERATING WEIGHT	5.7 t
ENGINE OUTPUT	54 kW (73.5 hp)
BUCKET CAPACITIES	1.0-1.55 m ³
TIPPING LOAD, STRAIGHT	4.4 t
TIPPING LOAD, ARTICULATED	3.9 t



Wheeled Loader TL100

Technical data

Engine	
Manufacturer, model	Deutz, BF4M 2011
Type	4-cylinder diesel engine, COM II/EPA II
Combustion	4-stroke cycle, direct fuel injection
Displacement	3100 cm ³
Net power rating at 2250 rpm (ISO 9249)	54 kW (73.5 hp)
Cooling system	external oil cooling
Electrical system	
Nominal voltage	12 V
Lighting system in compliance with German and European standards.	
Power transmission	
Hydrostatic drive, closed circuit, independent from loader hydraulics. Perfected driving automatics, automatic adjustment of drawbar pull and speed. Hydraulic motor power shift providing two speed ranges. Infinitely variable speed control forward and reverse. 4-wheel drive from reduction gear on rear axle via cardan shaft to front axle. Brake inching pedal.	
2 speed ranges:	
"Low"	0-6 km/h
"High"	0-20 km/h
4 speed ranges (high-speed version optional):	
"Low"	0-6 / 0-18 km/h
"High"	0-12 / 0-36 km/h
Axles	
Front: Rigid planetary final drive axle. Limited slip-type differential.	
Rear: Oscillating (with cushioning) planetary final drive axle, with integrated reduction gear. Limited slip-type differential.	
Oscillation	± 12°
Tires	
Standard	405/70 R 20 EM 01
Option	380/75 R 20 XMCL Michelin
Option	16/70-20 EM E91-2 Dunlop
Option	405/70 R 20 MPT 70 E Conti
Option	405/70 R 20 SPT 9 Dunlop
Non-standard tires available on request	
Brakes	
Service brake: Hydraulically actuated center-mounted drum brake, acting on all 4 wheels via 4-wheel drive.	
Auxiliary brake: Hydrostatic drive provides dynamic braking.	
Parking brake: Mechanically operated drum brake at front axle.	
Steering	
Articulated, 2 steering cylinders with final positioning damping on both sides, fully hydraulic through Load-Sensing priority valve, quick and easy steering even at engine idle-running speed.	
Total steering angle	80°
Fluid Capacities	
Fuel tank	110 l
Hydraulic system (incl. tank)	88 l

Operating data, standard equipment

Operating weight (ISO 6016)	5700 kg
Tipping load, straight, arms horizontal (ISO 14397-1)	4400 kg
Tipping load, articulated, arms horizontal (ISO 14397-1)	3900 kg
Total length, bucket on ground	5310 mm
Total width	1950 mm
Turning radius at outside bucket edge	4445 mm
Wheelbase	2220 mm
Total height (top of cab)	2765 mm

Hydraulic system

Max. pump capacity	72 l/min
Max. working pressure	250 bar

Control unit: Proportional hydraulic valve with 3 control circuits and high-speed control for tilting. Simultaneous, independent control of all movements. Single, four-way control lever (multi-function lever) for 1 tilt and 1 lift cylinders with integrated travel direction selector switch and switch for additional control circuit. Float position in control circuit "Lowering", electro-hydraulically operated. Additional control circuit including quick couplers and continuous operation function provided as standard.

Loader frame

Loader installation featuring true parallel linkage and integrated mechanical (optionally hydraulic) quick-attach system.

General-purpose bucket (ISO 7546)	1.00 m ³
Lift capacity at ground level (ISO 14397-2)	61,000 N
Breakout force at bucket edge (ISO 14397-2)	55,000 N

Fork Lift Attachment

Payload over the total lift and steering range	2400 (2600)* kg
Payload in transport position, approx. 300 mm above ground level, total steering range	3200* kg
Width of fork carrier	1240 mm
Length pallet forks (140x50 mm)	1120 mm
Stability factor	1.25
Payload determined on level ground = 80 % of tipping load, articulated	

Cab

Rubber-mounted full-vision steel cab, ROPS (acc. to ISO 3471) and FOPS** (acc. to ISO 3449) certified.	
Cab featuring two doors, electric windshield intermittent wipers and washer (front and rear), tinted panoramic safety glass, sliding window on left-hand side.	
Driver's seat with hydraulic cushioning and lap belt, weight-adjustable, in compliance with ISO 7096 and ISO 6683.	
Cab heating with 3-speed heater fan (choice fresh air/recirculating air) and windshield defroster, front and rear.	
Air conditioning and radio pre-installation.	
Tilt adjustable steering wheel.	
2 working floodlights, front.	
Sound level values in compliance with EC-directives.	
*With rear axle weights	
**FOPS-approved only with skylight guard (optional)	

Wheeled Loader TL100

Dimensions: General-Purpose Bucket

Rated capacity in compliance with ISO 7546: 1.00 m³
Max. density of material: 1.8 t/m³

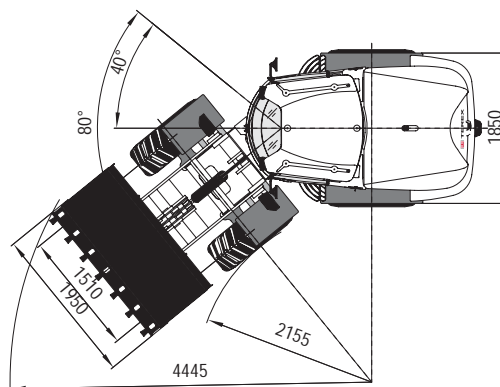
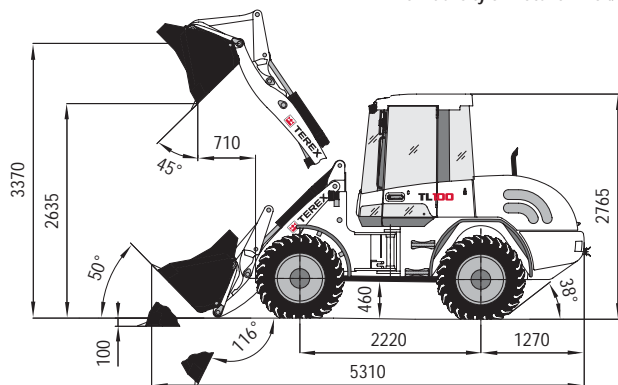

Fork Lift Attachment

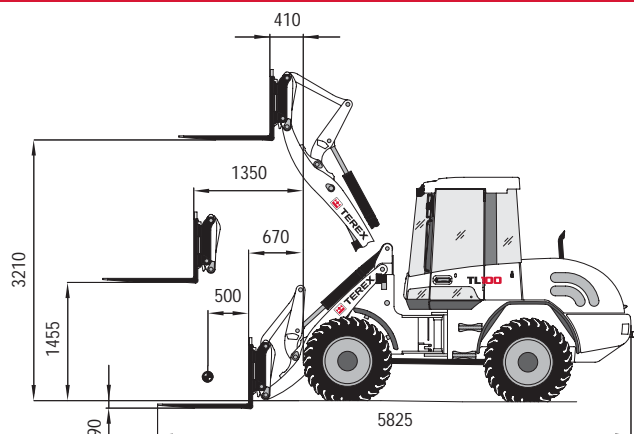

Payload over total lift range: 2400 (2600*) kg
Payload in transport position: 3200* kg
*With rear axle weights

Multi-Purpose Bucket

Rated capacity in compliance with ISO 7546: 0.90 m³
Max. density of material: 1.6 t/m³

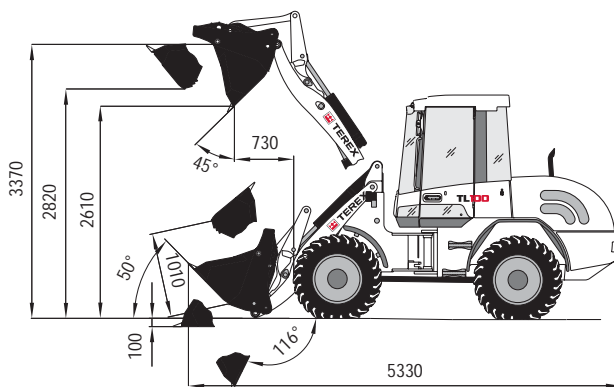

Bucket Type

	Capacity	Density	Width	Dump height
General-purpose bucket, QAS, teeth	1.00 m ³	1.8 t/m ³	1950 mm	2635 mm
General-purpose bucket, QAS, bolt-on cutting edge	1.00 m ³	1.8 t/m ³	1950 mm	2595 mm
Earth bucket, QAS, teeth	1.10 m ³	1.6 t/m ³	1950 mm	2585 mm
Earth bucket, QAS, bolt-on cutting edge	1.10 m ³	1.6 t/m ³	1950 mm	2545 mm
Light-material bucket, QAS, bolt-on cutting edge	1.35 m ³	1.2 t/m ³	2050 mm	2510 mm
Light-material bucket, QAS, bolt-on cutting edge	1.55 m ³	0.8 t/m ³	2200 mm	2485 mm
Multi-purpose bucket, QAS	0.90 m ³	1.6 t/m ³	1950 mm	2610 mm
Side-dump bucket, (QAS), without teeth	0.85 m ³	1.8 t/m ³	2050 mm	2515 mm
High-tip bucket, (QAS), without teeth	1.00 m ³	1.2 t/m ³	2050 mm	3835 mm
Quarry bucket, QAS	0.90 m ³	1.8 t/m ³	2050 mm	2610 mm
Compost bucket	1.05 m ³	1.8 t/m ³	2050 mm	2625 mm
Examples of Material Densities				
Granite, Sand (damp), Gravel (damp):	1.8 t/m ³	Coal, Slate:		1.2 t/m ³
Earth (damp), Sand (dry), Gravel (dry):	1.6 t/m ³	Coke, Wood chips (dry):		0.8 t/m ³



Terex GmbH Schaeffstrasse 8
D-74595 Langenburg, Germany

PHONE +49 (0)7905 / 58-0 FAX +49 (0)7905 / 58114
EMAIL info@terex-schaeff.com WEB terex-schaeff.de